



START HERE!

READ ME FIRST

Don't be a hero and muscle through this installation without reading these fitting instructions first! Improper installation of this gear may void certain aspects of your warranty.

Before you begin, take a moment and open all your Front Runner rack kit boxes and gather the assembly instructions for the various components.

A complete kit will contain:

1. A Front Runner Mounting System specific to your vehicle
2. A Front Runner Rack Tray or Load Bar Slats

This document will guide you through the assembly of the mounting system and assist you in fitting the roof rack tray or load bars to your specific vehicle.

Please refer to the next page for a list of all the components, quantities and tools required.

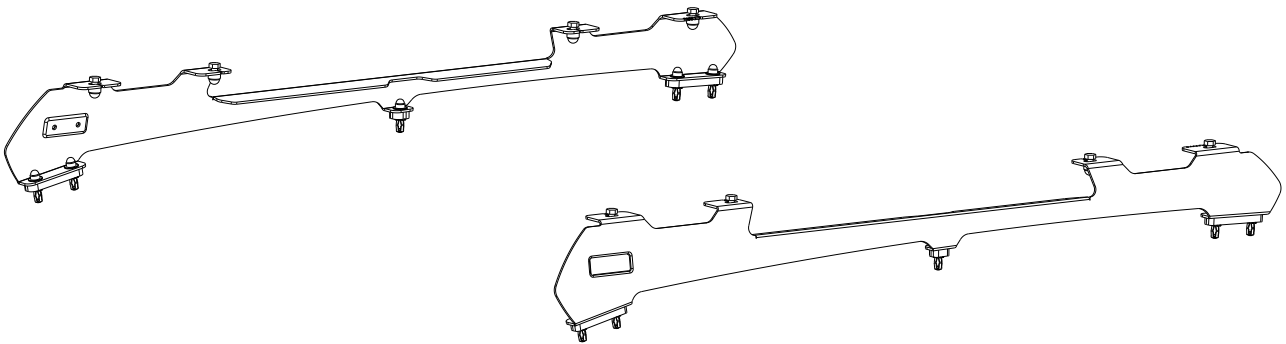

IMPORTANT WARNING! ⚠️

IT IS CRITICAL THAT ALL FRONT RUNNER PRODUCTS BE PROPERLY AND SECURELY ASSEMBLED AND ATTACHED TO YOUR VEHICLE. IMPROPER ATTACHMENT COULD RESULT IN AN AUTOMOBILE ACCIDENT, AND COULD CAUSE SERIOUS BODILY INJURY OR DEATH. YOU ARE RESPONSIBLE FOR ASSEMBLING AND SECURING ALL FRONT RUNNER PRODUCTS TO YOUR VEHICLE, CHECKING THE ATTACHMENTS PRIOR TO USE, AND PERIODICALLY INSPECTING THE PRODUCTS FOR ADJUSTMENT, WEAR AND DAMAGE. THEREFORE, YOU MUST READ AND UNDERSTAND ALL OF THE INSTRUCTIONS AND PRECAUTIONS SUPPLIED WITH YOUR FRONT RUNNER PRODUCT PRIOR TO INSTALLATION OR USE. IF YOU DO NOT UNDERSTAND ALL OF THE INSTRUCTIONS AND CAUTIONS, OR IF YOU HAVE NO MECHANICAL EXPERIENCE AND ARE NOT THOROUGHLY FAMILIAR WITH THE INSTALLATION PROCEDURES, YOU SHOULD HAVE THE PRODUCT INSTALLED BY A PROFESSIONAL INSTALLER OR OTHER QUALIFIED PERSONNEL.

NOTE: Front Runner will not be responsible for any damage caused by the failure to install the product according to these instructions.

Please call us if you have any questions about the installation of this product.

1

GET ORGANIZED

IN THE BOX

1	2 X	Foot Rail - 1 LH & 1 RH
2	8 X	M8 x 20 Hex Bolt
3	8 X	M8 x 16 x 1.6 Flat Washer
4	8 X	M8 Nyloc Nut
5	8 X	M8 Nut Cap
6	4 X	Large Spacer - 10mm
7	2 X	Small Spacer - 10mm
8	10 X	M6 x 19 x 1 Flat Washer
9	10 X	M6 Spring Washer
10	10 X	M6 x 35 Hex Bolt
11	10 X	M6 Nut Cap
12	11 X	M6 Jack Nut
13	1 X	M6 Jack Nut Tool
14	2 X	M6 x 30 Button Head Bolt

TOOLS NEEDED

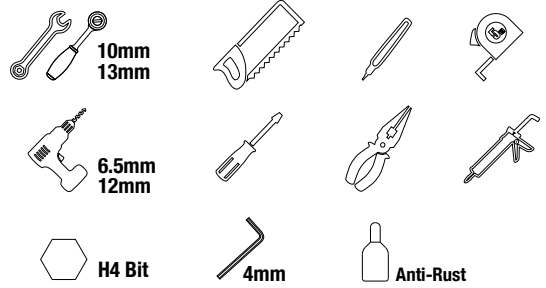
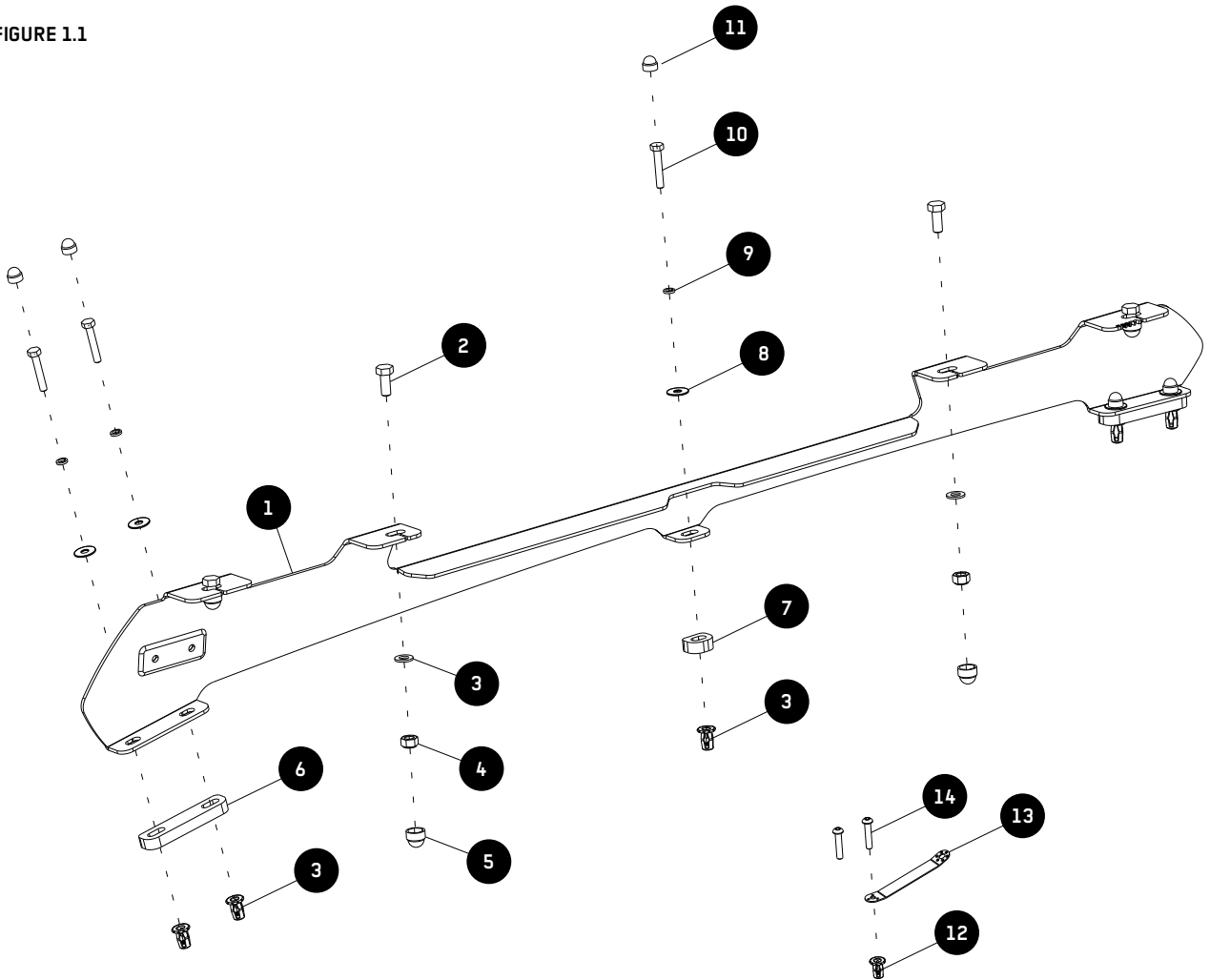

FIGURE 1.1



2.1



Using a flat screw driver and starting from the front of the vehicle, lift and remove the two ditch moldings running along either side of the roof.

2.2

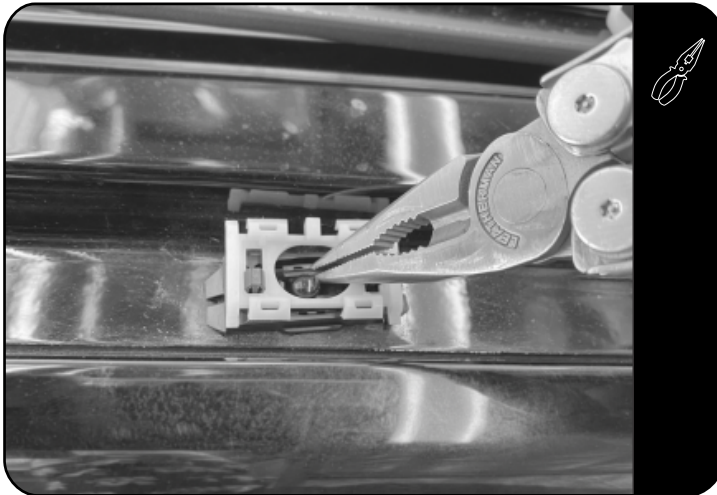

Remove all the retaining clips using a long nose plier as shown.

2.3

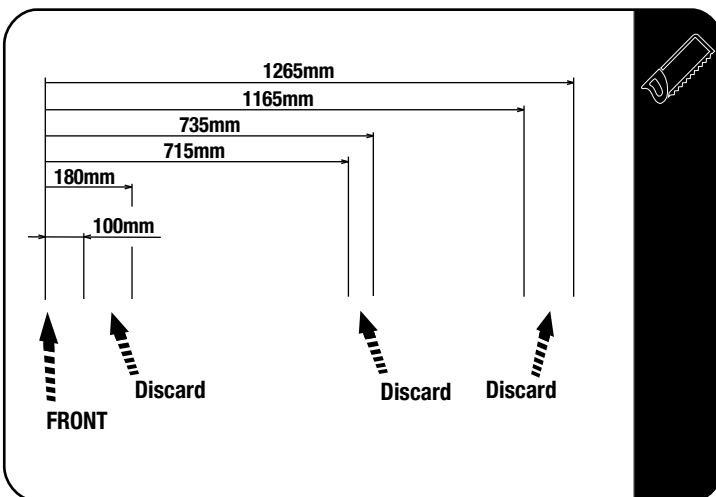

Lay the left-hand ditch moulding on an even surface. From the front tip of the ditch moulding, measure and mark as shown.

Using a hacksaw, cut the ditch moulding at each marking.

Discard the three smaller pieces and refit the retaining clips to the four cut ditch mouldings making sure the retaining clips line up with the clip pins in the ditch.

Repeat this for the right-hand moulding.

2

FIT AND SECURE

2.4

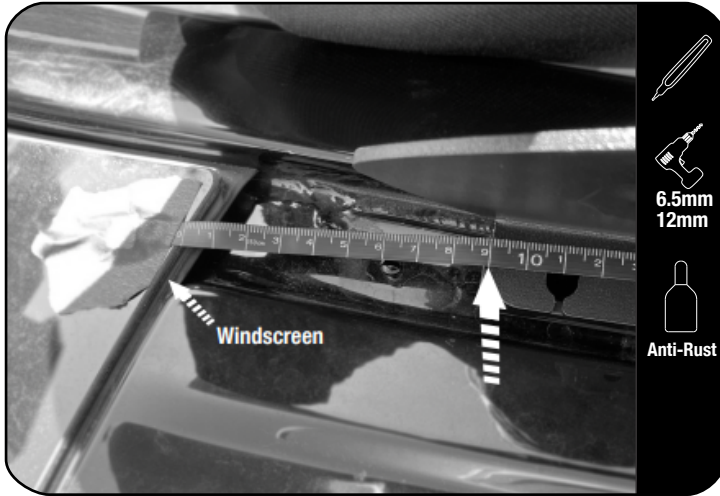

Place the Spacers (Item 6 & 7) in the ditch and place the Foot Rail (Item 1) on top with the Spacers (Item 6) under the front and rear Foot mounts and Spacer (Item 7) under the single Foot mount. Position the Foot Rail 90mm from the top edge of the windscreen as shown. Centralize the slotted holes in the Spacers with the slotted holes in the Foot Rail feet.

Carefully remove the Foot Rails and mark the slot centers of all the Spacers in the ditch.

Drill a 6.5mm pilot hole in the center of the markings. Open the holes using a 12mm Drill.

Apply Anti-Rust on all holes.

2.5

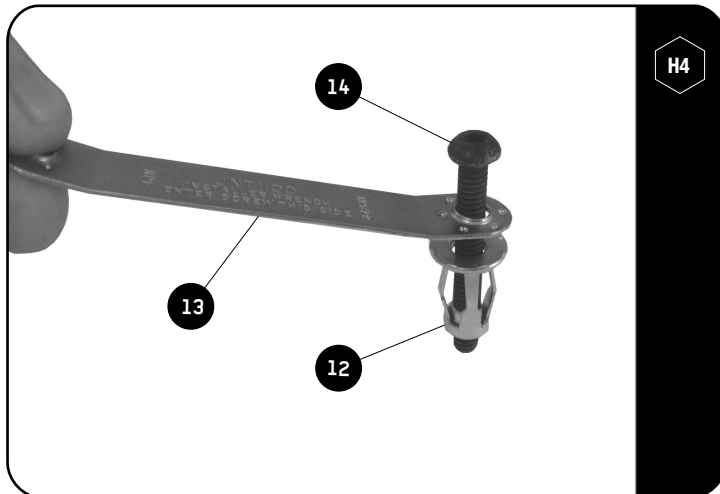

Insert the M6 Button Head Bolt (Item 14) into the one side of the Jack Nut Tool (Item 13). Loosely fit a Jack Nut (Item 12) to the Button Head Bolt (Item 14) as shown. Using the Jack Nut Tool and a M6 x 30 Button Head Bolt, insert the M6 Jack Nuts into all 8 holes. Place the assembly into the hole drilled. Using a Battery Powered Screw Driver and a H4 Allen Key Bit, set the Jack Nut into the hole while holding onto the handle of the Jack Nut Tool.



Make sure the Jack Nut has pulled up all the way to the inside skin of the roof panel.

2.6



Place a bead of silicone around each of the Jack Nut openings inserted in 2.5.

Place the three Spacers back on top of the inserted Jack Nut. Fit the four pieces of the ditch moulding cut in 2.3.

2**FIT AND SECURE**

2.7

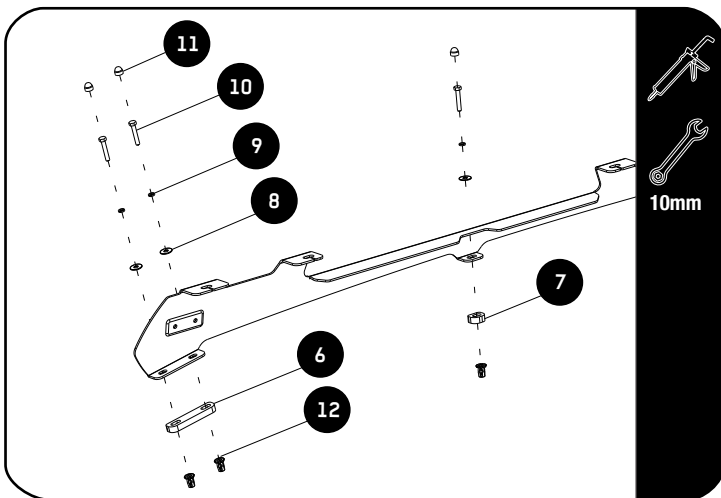

Place the Foot Rail (Item 1) on top of the Spacers (Item 6 & 7).

Apply silicone on the threads of the M6x35 Hex Bolts (Item 10) and secure the Foot Rail using M6 Spring Washers, M6x19x1SS Flat Washers and Jack Nuts inserted (Items 8, 9 & 12).

Do this on both the left and right side of the vehicle.

Finish off by placing M6 Nut Caps (Item 11) on the M6 Hex Bolt heads.

To fit the Rack, proceed to Step 3.

3**FIT AND SECURE**

3.1

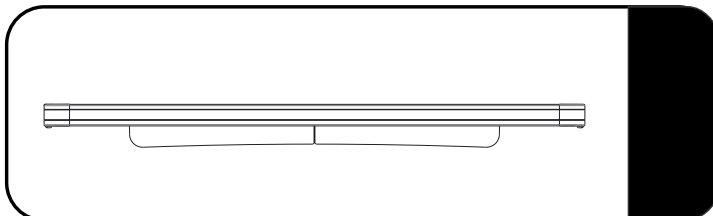

Make sure that the wind deflector is installed before you proceed to the next step.

3.2

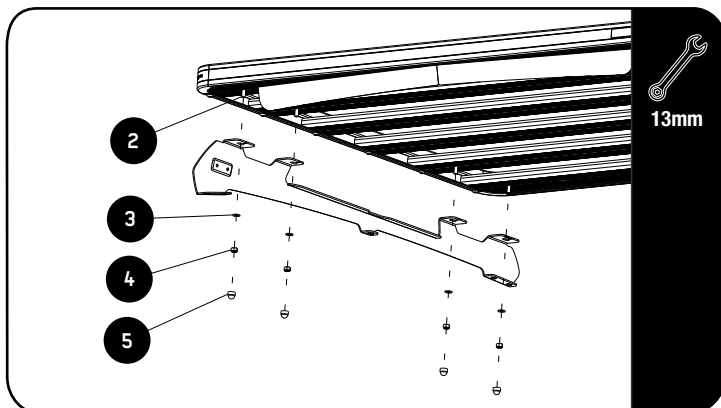

Fit your Roof Rack to the Foot Rails using M8x20 Hex Bolts, M8x16x1.6SS Flat Washers and M8 Nyloc Nuts (Items 2, 3 & 4) as shown.

3.3

Center the rack and tighten fully. Finish off by fitting the M8 Nut Caps (Item 5) on the M8 Nyloc Nuts.



4

INSTALL OTHER VEHICLE AND RACK ACCESSORIES

Now's the time to visit your favorite Front Runner Dealer in person or online.

IMPORTANT!

FRONT RUNNER RACK KITS OFTEN HAVE A HIGHER LOAD RATING THAN THE VEHICLES THEY ARE MOUNTED TO. PLEASE REFER TO YOUR SPECIFIC VEHICLE MANUFACTURER FOR A RECOMMENDED ROOF RATING. FRONT RUNNER CANNOT BE RESPONSIBLE FOR IMPROPER LOADING BEYOND THE VEHICLE MANUFACTURER'S STATED LOAD CAPACITY.

Be sure to tag us. We love to see our gear in action! #FrontRunnerOutfitters #BornToRoam

Share your adventures on: 