

START HERE!

READ ME FIRST

Don't be a hero and muscle through this installation without reading these fitting instructions first! Improper installation of this gear may void certain aspects of your warranty.

Before you begin, take a moment and open all your Front Runner rack kit boxes and gather the assembly instructions for the various components.

A complete kit will contain:

1. A Front Runner Mounting System specific to your vehicle
2. A Front Runner Rack Tray or Load Bar Slats

This document will guide you through the assembly of the mounting system and assist you in fitting the roof rack tray or load bars to your specific vehicle.

Please refer to the next page for a list of all the components, quantities and tools required.

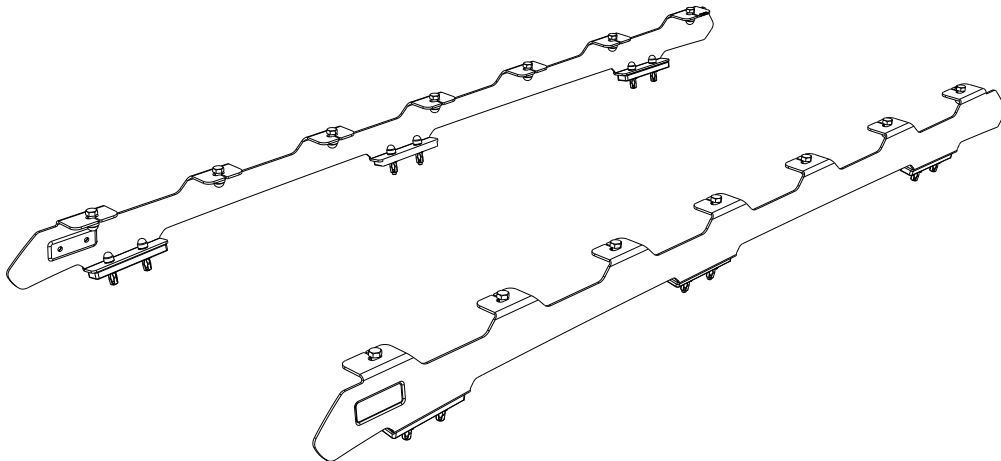

IMPORTANT WARNING!

IT IS CRITICAL THAT ALL FRONT RUNNER PRODUCTS BE PROPERLY AND SECURELY ASSEMBLED AND ATTACHED TO YOUR VEHICLE. IMPROPER ATTACHMENT COULD RESULT IN AN AUTOMOBILE ACCIDENT, AND COULD CAUSE SERIOUS BODILY INJURY OR DEATH. YOU ARE RESPONSIBLE FOR ASSEMBLING AND SECURING ALL FRONT RUNNER PRODUCTS TO YOUR VEHICLE, CHECKING THE ATTACHMENTS PRIOR TO USE, AND PERIODICALLY INSPECTING THE PRODUCTS FOR ADJUSTMENT, WEAR AND DAMAGE. THEREFORE, YOU MUST READ AND UNDERSTAND ALL OF THE INSTRUCTIONS AND PRECAUTIONS SUPPLIED WITH YOUR FRONT RUNNER PRODUCT PRIOR TO INSTALLATION OR USE. IF YOU DO NOT UNDERSTAND ALL OF THE INSTRUCTIONS AND CAUTIONS, OR IF YOU HAVE NO MECHANICAL EXPERIENCE AND ARE NOT THOROUGHLY FAMILIAR WITH THE INSTALLATION PROCEDURES, YOU SHOULD HAVE THE PRODUCT INSTALLED BY A PROFESSIONAL INSTALLER OR OTHER QUALIFIED PERSONNEL.

NOTE: Front Runner will not be responsible for any damage caused by the failure to install the product according to these instructions.

Please call us if you have any questions about the installation of this product.



1 GET ORGANIZED

IN THE BOX

1	2 X	Foot Rail LH + RH
2	6 X	Spacer
3	13 X	M6 Jack Nut Long
4	12 X	M6 x 12 x 1 Flat Washer
5	12 X	M6 Spring Washer
6	12 X	M6 x 35 Hex Head Bolt
7	14 X	M8 x 20 Hex Head Bolt
8	14 X	M8 x 16 x 1.6 Flat Washer
9	14 X	M8 Nyloc Nut
10	14 X	M8 Nut Cap
11	12 X	M6 Nut Cap
12	1 X	Jack Nut Tool
13	1 X	M6 x 35 Button Head Bolt

TOOLS NEEDED

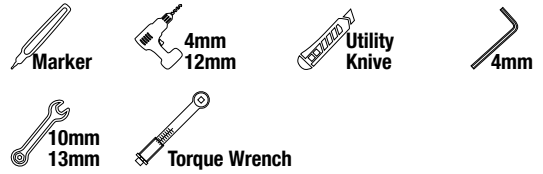
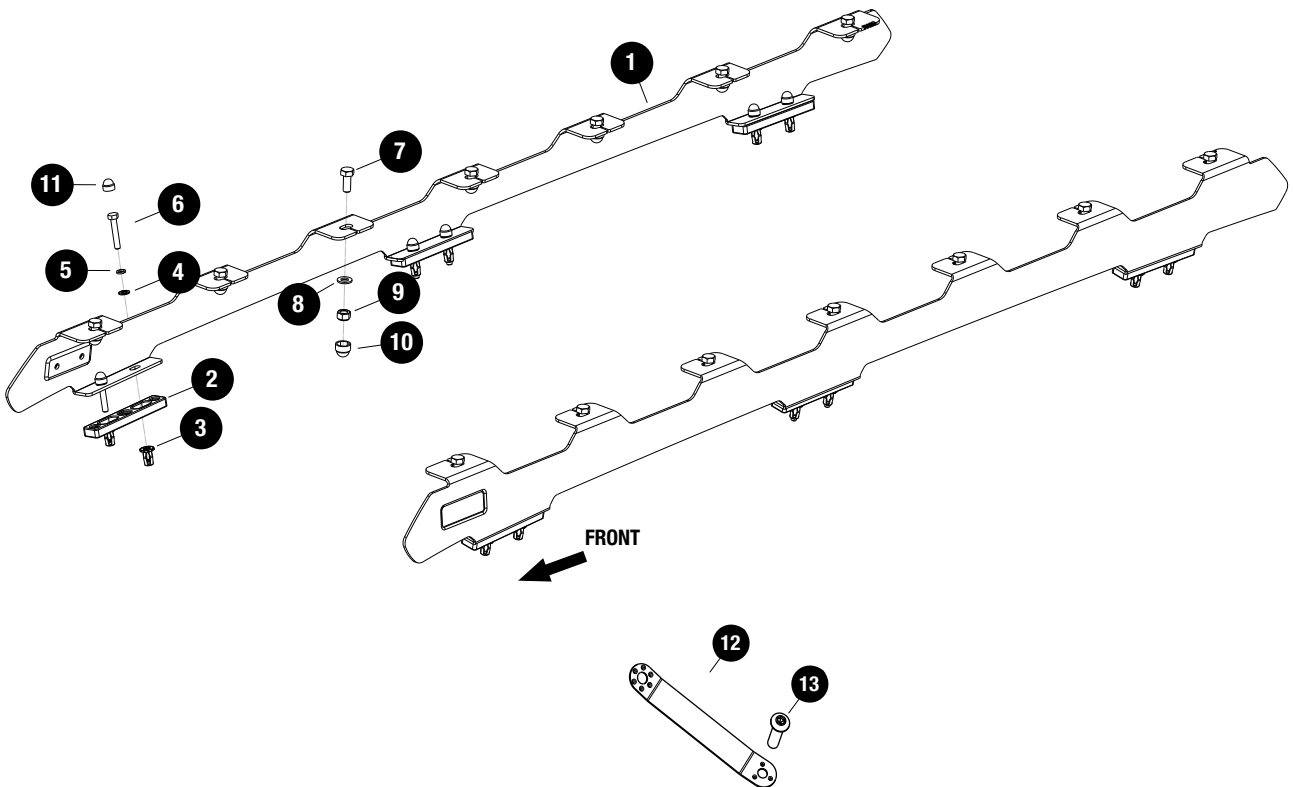
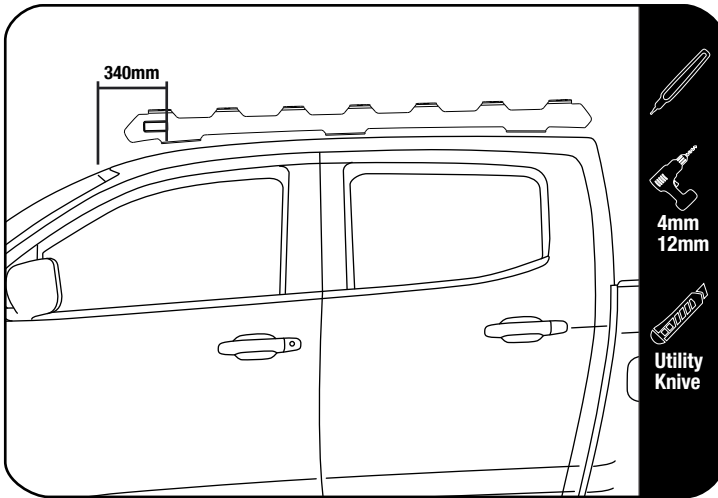

FIGURE 1.1



FIT AND SECURE

2.1



Starting at the top edge of the vehicle's windscreen, measure and mark the dimension as shown onto both LH / RH ditch centre's.

Place the foot rail on the vehicles roof, lining up the front slot centre with the mark you made and mark the centre of the remaining 3 slots on the Foot Rail. Do this on both the LH & RH side.

Mark the front and rear of each foot tab. Remove the Foot Rail (Item 1) and drill 4mm Pilot holes on the markings made earlier.

Carefully Remove the molding sections and cut the molding on the markings you made.

Refit the ditch molding and open the 4mm holes to 12mm.

2.2

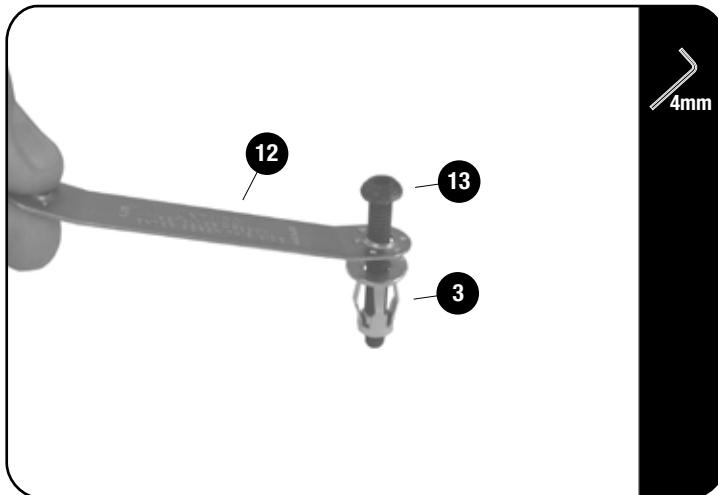

Insert a M6 x 30 Button Head Bolt (Item 13) into the Jack Nut Tool (Item 12) and loosely fit a Jack Nut (Item 3) to the button head bolt as shown.

Using a cordless driver and a 4mm allen cordless bit, set the jack nut into the hole while holding the Jack Nut Tool, to prevent the Jack Nut from turning.



Make sure the Jack Nut has pulled up all the way to the inside skin of the roof panel.

2.3

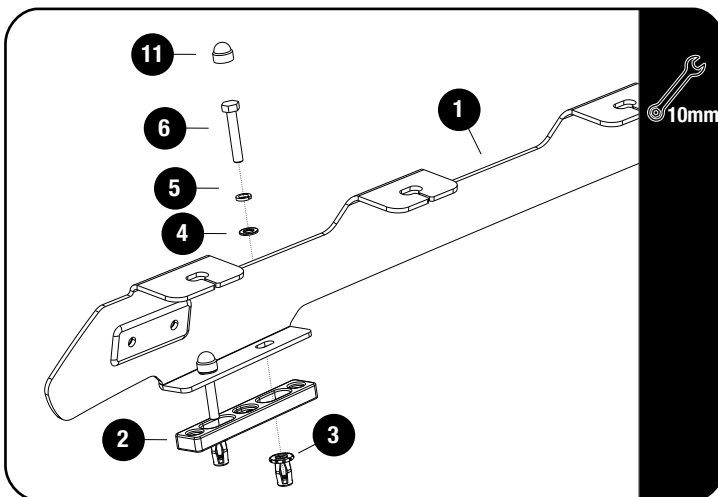

Tightening Torque:

M6 : 8-10Nm / 5.9 ft lb - 7.38 ft lb



Place the spacers as shown in Fig 1.1 in the vehicles ditch, aligning the the spacers with the holes in the vehicles roof.

Place a bead of silicone along the threads of the M6 x 35 Hex Bolts and secure the rack using M6 x 35 Hex Bolts, M6 Spring Washers and M6 x 19 x 1 Flat Washers.

Place M6 Nut Caps (Item 9) over all hex bolts.

3

FIT AND SECURE

3.1

Refer to RRSUNI when assembling your Slimline II Tray.



3.2

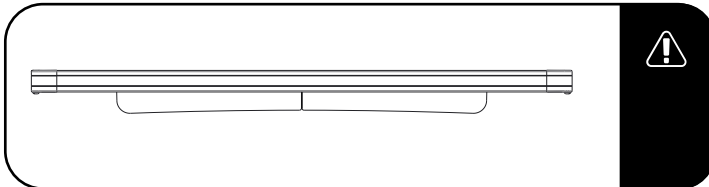

Make sure that the wind deflector is installed before you proceed to the next step.

3.3

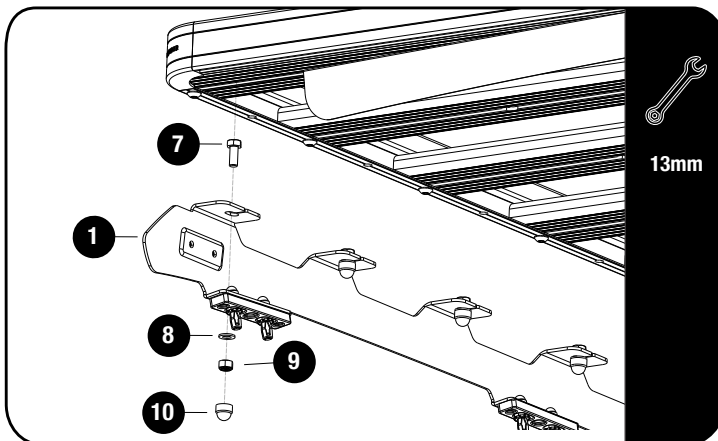

Tightening Torque:

M8 : 15-20Nm / 11.06 ft lb - 14.75 ft lb



Fit your roof rack to the Foot Rails using M8 x 20 Hex Bolts, M8 x 16 x 1.6SS Flat Washers and M8 Nyloc Nuts (Items 6, 8 & 9) as shown.

3.4

Center the rack and tighten fully. Use M8 Nut Caps (Items 10) to finish off the nuts.



5

INSTALL OTHER VEHICLE AND RACK ACCESSORIES

Now's the time to visit your favorite Front Runner dealer in person or online.

IMPORTANT!

FRONT RUNNER RACK KITS OFTEN HAVE A HIGHER LOAD RATING THAN THE VEHICLES THEY ARE MOUNTED TO. PLEASE REFER TO YOUR SPECIFIC VEHICLE MANUFACTURER FOR A RECOMMENDED ROOF RATING. FRONT RUNNER CANNOT BE RESPONSIBLE FOR IMPROPER LOADING BEYOND THE VEHICLE MANUFACTURER'S STATED LOAD CAPACITY.

Be sure to tag us. We love to see our gear in action! #FrontRunnerOutfitters #BornToRoam

Share your adventures on: